

AUTO LEVEL
AT-G4
AT-G6

Foreword

Thank you for purchasing the TOPCON GREEN LABEL Auto Level AT-G Series. For the best performance of the instruments, please read these instructions carefully and keep them in a convenient location for future reference.

General Handling Precautions

- Before starting work or operation, be sure to check that the instrument is functioning correctly with normal performance.

Display for safe use

In order to encourage the safe use of products and prevent any danger to the operator and others or damage to properties, important warnings are put on the products and inserted in the instruction manuals. We suggest that everyone understand the meaning of the following displays and icons before reading the "Safety Cautions" and text.

Display	Meaning
WARNING	Ignoring or disregard of this display may lead to death or serious injury.
CAUTION	Ignoring or disregard of this display may lead to personal injury or physical damage to the instrument.

- 1) Injury refers to hurt, burn, electric shock, etc.
- 2) Physical damage refers to extensive damage to buildings or equipment and furniture.

Safety Cautions

WARNING

- **Cause eye injury or blindness.**
Do not look at the sun through a telescope. It is suggested to pay care specially at the time the position of the sun is low such in the morning or evening, or at the time the sunlight is coming directly to the objective lens of the instrument, cut off the sunlight by your hand or use an umbrella in such case.
- **Do not use the staff in conditions of thunder and lightning.**
As this is an electric conductor, thunderbolt can cause serious injury or death.
- **Keep the staff away from electric facilities such as a high voltage wire or substation.**
As this is an electric conductor, there is danger of electric shock.

CAUTION

Risk of injury by overturn the carrying case.
Do not stand or sit on the carrying cases.

Please note that the tips of tripod can be hazardous, be aware of this when setting up or carrying the tripod.

Risk of injury by falling down the instrument or case.
Do not use a carrying case with a damaged which belts, grips or latches.

A plumb bob can cause an injury to a person if used incorrectly.

Ensure that you mount the Tribach correctly, failing to do so may result in injury if the tribrach were to fall over.

It could be dangerous if the instrument falls over, please check that you fix the instrument to the tripod correctly.

Risk of injury by falling down a tripod and an instrument.
Always check that the screws of tripod are tightened.

User

- 1) This product is for professional use only!
The user is required to be a qualified surveyor or have a good knowledge of surveying, in order to understand the user and safety instructions, before operating, inspecting or adjusting.
- 2) Wear the required protectors (safety shoes, helmet, etc.) when operating.

Exceptions from Responsibility

- 1) The user of this product is expected to follow all operating instructions and make periodic checks of the product's performance.
- 2) The manufacturer, or its representatives, assumes no responsibility for results of a faulty or intentional usage or misuse including any direct, indirect, consequential damage, and loss of profits.
- 3) The manufacturer, or its representatives, assumes no responsibility for consequential damage, and loss of profits by any disaster, (an earthquake, storms, floods etc.). A fire, accident, or an act of a third party and/or a usage any other usual conditions.
- 4) The manufacturer, or its representatives, assumes no responsibility for any damage, and loss of profits due to a change of data, loss of data, an interruption of business etc., caused by using the product or an unusable product.
- 5) The manufacturer, or its representatives, assumes no responsibility for any damage, and loss of profits caused by usage except for explained in the user manual.
- 6) The manufacturer, or its representatives, assumes no responsibility for damage caused by wrong movement, or action due to connecting with other products.

Standard set component

Model AT-G4 or AT-G6	1each
Plastic carrying case	1each
Lens cap	1each
Plumb bob set.....	1each
Hexagonal wrench.....	1each
Silicon cloth	1each
Vinyl cover	1each
Instruction manual	1each

Specifications

Telescope	
Overall length	192mm(AT-G4) 193mm(AT-G6)
Image	Erect
Effective diameter lens	30mm
Magnification	26X(AT-G4) 24X(AT-G6)
Field of view	1°30'
Resolving power	3.5"(AT-G4) 4"(AT-G6)
Minimum focus	0.5m
Horizontal circle	
Diameter	117mm
Minimum reading	1°
Automatic compensation mechanism	
Range	±15'
Measuring accuracy	
1 km double run	±2.0mm
Circular level	
Sensitivity	8'/2mm
Other	
Protection against water and dust.....	IPX7 (Based on the standard IEC60529)
Weight	
Instrument	1.6kg
Plastic carrying case	1.3kg

Nomenclature

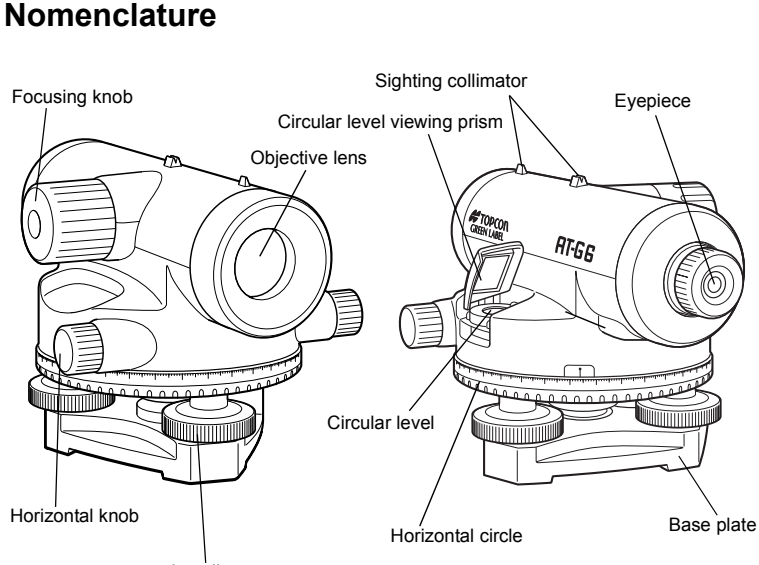

Operating

Setting

- 1 First position the tripod leg and then spread the other two so as to make the tripod head almost level.
- 2 Firmly position the tripod legs on the ground, then tighten the screws.
- 3 Place the instrument on the tripod head, then screw the tripod screw into the instrument bottom for securing it to the tripod.
- 4 Use a plumb to match the instrument center with the measuring point when a horizontal scale is used.
- 5 Use the three leveling screws to center the circular level. When a dome head tripod is used loosen the tripod screw a little, slide the instrument, center the bubble, looking at the level, then the tripod screw to secure the instrument.

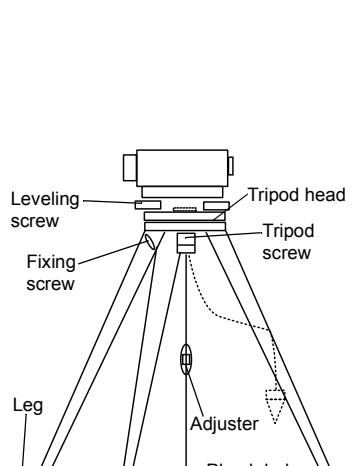

Collimating

- 1 Direct the telescope to bright object and turn the eyepiece ring so that the reticle in the eyepiece is clearly seen.
- 2 Turn the instrument manually and align the target through the sighting collimator.
- 3 Focus the target with the focusing knob.
- 4 Turn the horizontal knob to match the reticle with the target.

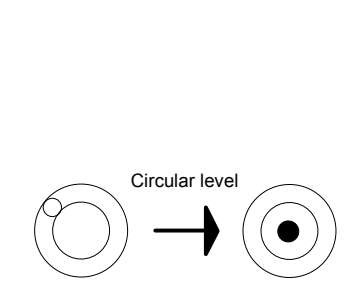

Measuring (Height)

- In order to measure the difference in height between point A and point B.
- 1 Set up the instrument almost in the middle of the points.
 - 2 Provide a leveling rod at point A and B, one each, collimate them and read the horizontal line of the reticle.
 - 3 Suppose the reading at point A is a and at point B is b, and the difference in height between the two points will be: a - b

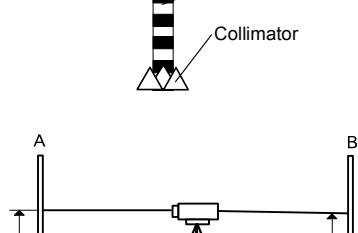

Note:

Be sure that the leveling rods are almost vertical. It is recommended to position the level almost in the center of points A and B to avoid influence by the axis of vision on the measuring even if it varies a little in terms of being horizontal.

Measuring (Horizontal angle)

The horizontal circle has a clockwise graduation from 0° to 359° (0 to 399g) numeric indications every 10 degrees (10g).

- 1 Attach the plumb bob string to the plumb bob hook and adjust the string length.
- 2 Loosen the tripod screw a little, and move the instrument according to the apex to match the plumb bob end with the measuring point.
- 3 Re-tighten the tripod screw.
- 4 Use the leveling screws to center the circular level.
- 5 Sight target A and turn the horizontal circle to bring the scale to "zero". Sight target B, and then the reading 30° (33g) will be a horizontal angle between points A and B.

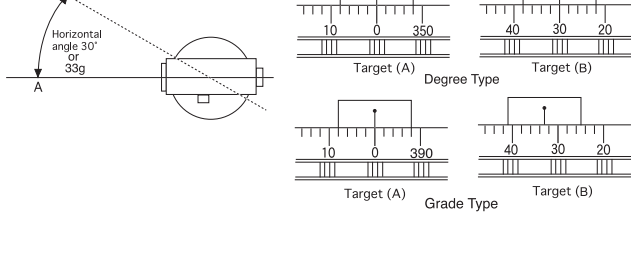

Leveling (for 4 points)

- 1 Set up the instrument almost in the center of the 4 points.
- 2 Match the bottom of a rod with pile A marked line (a).
- 3 Sight the rod and mark (e) on the rod that coincides with the horizontal line of the reticle.
- 4 Place the rod at B and move it vertically to sight the marked line (e).
- 5 Mark (b) in ink on pile B according to the rod bottom.
- 6 Mark piles C and D in the above manner.

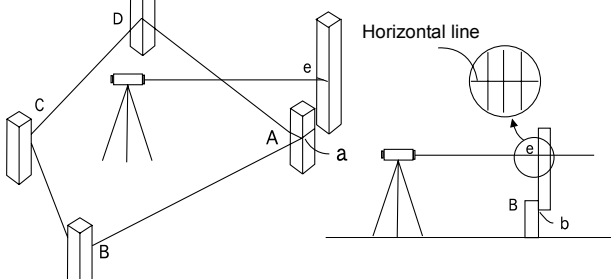

Checking and adjusting

Operation of the automatic compensating mechanism

- 1 Adjust the three leveling screw to center the circular level.
- 2 Sight the target, then strike the tripod slightly by hand.
- 3 The reticle may swing, but it will soon return to its position. This provides that the mechanism is functioning

Checking and adjustment of the circular level

Checking

- 1 Operate the three leveling screws to center the circular level. Turn the instrument 180°.

No adjustment is necessary if the bubble lines in the center circle. If not, take the following measures for adjusting.

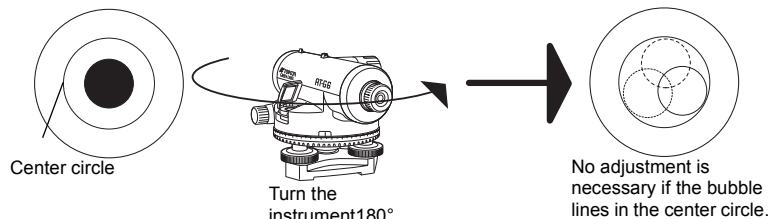

Adjusting

- 1 Use the hexagonal wrench to turn the three circular level adjusting screws to center the bubble by a half that it is out-of-level.
- 2 Turn the three leveling screws to bring the bubble to the center. Check the instrument again by turning 180°, and adjustment is satisfactory if the bubble remains at the center. If not, repeat the adjusting procedure

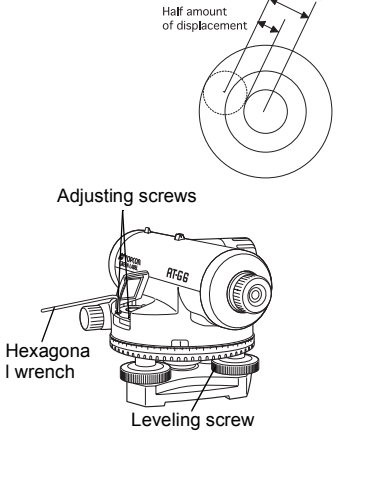

Collimation of the instrument

Checking

- 1 leveling rods A and B about 30 to 40 meters away from each other, and set up the instrument with a tripod almost in the middle between the rods.
- 2 Use the leveling screws to center the circular level.
- 3 Sight the rods for A and B reading. (a1, b1)
- 4 Move the instrument to a position 2 to 3 meters (7 to 8 feet) away from point A.
- 5 Center the bubble again.
- 6 Sight the rods for reading again. (a2, b2)
- 7 No adjustment should be necessary if the difference between to pairs of readings is equal: $b1 - a1 = b2 - a2$. If not, make the following adjustment.

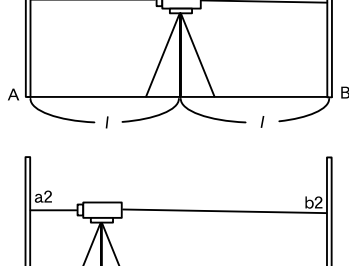

Adjusting

- 1 Calculate $b2' = a2 + (b1 - a1)$ and apply to the rod farther away. Use adjusting pin to turn the reticle adjusting screw for collimating b'.
- 2 Follow "Checking" again, and confirm that the adjustment is satisfactory.

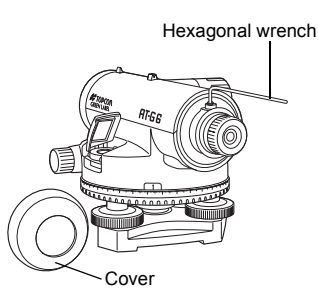

<p>TOPCON POSITIONING SYSTEMS, INC. 7400 National Drive, Livermore, CA 94551, U.S.A. Phone: 925-245-8300 Fax: 925-245-8599 www.topcon.com</p> <p>TOPCON CALIFORNIA 3380 Industrial Blvd, Suite 105, West Sacramento, CA 95691, U.S.A. Phone: 916-374-8575 Fax: 916-374-8329</p> <p>TOPCON EUROPE POSITIONING B.V. Essebaan 11, 2906 LJ Capelle a/d IJssel, The Netherlands. Phone: 010-458-5077 Fax: 010-284-4949 www.topconeuropa.com</p> <p>IRELAND OFFICE Unit 69 Western Parkway Business Center Lower Ballymount Road, Dublin 12, Ireland Phone: 01460-0021 Fax: 01460-0129</p> <p>TOPCON DEUTSCHLAND G.m.b.H. Gieselerallee 31, 47877 Willich, GERMANY Phone: 02154-885-100 Fax: 02154-885-111 info@topcon.de www.topcon.de</p> <p>TOPCON S.A.R.L. 89, Rue de Paris, 92585 Clichy, Cedex, France. Phone: 33-1-41069490 Fax: 33-1-47390251 topcon@topcon.fr</p> <p>TOPCON ESPAÑA S.A. Frederic Mospou 5, ED. Euro 3, 08960, Sant Just Desvern, Barcelona, Spain. Phone: 93-473-4057 Fax: 93-473-3932 www.topconesp.com</p> <p>TOPCON SCANDINAVIA A. B. Neongatan 2 S-43151 Mölndal, SWEDEN Phone: 031-7102000 Fax: 031-7102049</p> <p>TOPCON (GREAT BRITAIN) LTD. Topcon House Kennet Side, Bone Lane, Newbury, Berkshire RG14 5PX U.K. Phone: 44-1635-551120 Fax: 44-1635-551170 survey.sales@topcon.co.uk laser.sales@topcon.co.uk</p>	<p>TOPCON SOUTH ASIA PTE. LTD. Blk 192 Pandan Loop, #07-01 Pantech Industrial Complex, Singapore 128381 Phone: 62780222 Fax: 62733540 www.topcon.com.sg</p> <p>TOPCON AUSTRALIA PTY., LTD. Unit 19, 4 Avenue of Americas Newington NSW 2127, Australia Phone: 02-8748-8777 Fax: 02-9647-2926 www.topcon.com.au</p> <p>TOPCON INSTRUMENTS (THAILAND) CO., LTD. 77/162 Sinn Sathorn Tower, 37th Fl., Kruengthoraburi Rd., Klongtoey, Klongsarn, Bangkok 10600 Thailand. Phone: 02-440-1152-7 Fax: 02-440-1158</p> <p>TOPCON INSTRUMENTS (MALAYSIA) SDN. BHD. Excella Business Park Block C, Ground & 1st Floor, Jalan Ampang Putra, Taman Ampang Hill, 55100 Kuala Lumpur, MALAYSIA Phone: 03-42701068 Fax: 03-42704508</p> <p>TOPCON KOREA CORPORATION 2F Yoseoung Bldg., 1595-3, Seocho-Dong, Seocho-gu, Seoul, 137-876, Korea. Phone: 82-2-2055-8321 Fax: 82-2-2055-0319 www.topcon.co.kr</p> <p>TOPCON OPTICAL (H.K.) LIMITED 2-4/F Meeco Industrial Bldg., No. 53-55 Au Pui Wan Street, Fo Tan Road, Shatin, N.T., Hong Kong Phone: 3690-1328 Fax: 2690-2221 www.topcon.com.hk</p> <p>TOPCON CORPORATION BEIJING OFFICE Building A No.9 Kangding Street Beijing Economic Technological Development Area, Beijing, China 100176 Phone: 10-6780-2799 Fax: 10-6780-2790</p> <p>TOPCON CORPORATION BEIRUT OFFICE P. O. BOX 70-1002 Antelias, BEIRUT, LEBANON Phone: 961-4-52325/961-4-52326 Fax: 961-4-521119</p> <p>TOPCON CORPORATION DUBAI OFFICE C/O Atlas Medical FZCO., P. O. Box 54304, C-25, Dubai Airport Free Zone, UAE</p>
--	---